

Femtosecond planar electron beam source for micron-scale dielectric wake field accelerator

T. C. Marshall

Department of Applied Physics, Columbia University, New York City 10027

Changbiao Wang

Department of Physics, Yale University, New Haven, CT 06520-8120

J. L. Hirshfield

*Department of Physics, Yale University, New Haven, CT 06520-8120
Omega-P, Inc., Suite 100, 345 Whitney Avenue, New Haven CT 06511*

A new accelerator LACARA is under construction at ATF, Brookhaven National Laboratory. LACARA is to be powered by a 1 TW CO₂ laser, and will utilize a 6-T 2-m long solenoidal magnetic field. For a 50 MeV injected electron bunch, LACARA is expected to produce a 100 MeV 1 ps gyrating beam with ~3% energy spread. Beam electrons advance in phase at the laser frequency, executing one cycle each 35 fs. A beam stop with a small off-axis channel will transmit a short beam pulse every optical cycle, thereby producing a train of about 30, 3.5 fs, 1-3 pC microbunches for each laser pulse. One application for this train of microbunches obtained from a LACARA-type device involves focusing a portion of the beam using a magnetic quadrupole into a rectangular cross-section having a narrow dimension of a few microns and a height of a few hundred microns. These microbunches may be injected into a planar dielectric-lined waveguide where cumulative buildup of wake fields can lead to an accelerating gradient > 1 GV/m. This proposed vacuum-based wake field structure is mechanically rigid and capable of accurate microfabrication, factors important in staging a large number of accelerator modules. Furthermore, the accelerating gradients it promises are comparable with those for plasma accelerators. A LACARA unit for preparing suitable bunches at 500 MeV is described. Physics issues are discussed including bunch spreading and transport, bunch shaping, aperture radiation, dielectric breakdown, and bunch stability in the rectangular wake field structure.

PACS Codes: 41.75. Jv, 41.75. Lx, 41.75. Ht, 96.50. Pw

I. Introduction

New techniques for accelerating electrons or positrons using lasers promise very high accelerating gradients (> 1 GeV/m). Such techniques can be sorted into three categories: those using plasmas,¹ vacuum structure-based accelerators, or “far-field” devices such as the IFEL. The first two make use of “structures” of small dimension, whether formed transiently by a laser beam in the plasma, or by a permanent material structure which surrounds the electron bunch in vacuum; the latter is designed to be excited by fields at optical/IR wavelengths. We describe here a technique to prepare a train of bunches of electrons at high energy, each of which is approximately 1 micron (3.5 fs) in length, and which can be used to excite small material structures in vacuum so as to provide GeV/m gradients. The use of plasma is not necessary, and the new source of tightly-bunched electrons should provide high accelerating gradients in fixed optically-resonant structures which can be made and staged precisely and reproducibly using microcircuit techniques. A specific accelerator concept which can benefit by using laser-wavelength scale structures is

the dielectric wakefield accelerator, either in a multiple-bunch single-pass configuration^{2, 3} or as a resonator.⁴

Wakefield accelerators are generally attractive because no external source of energy (laser energy here) is used to excite the structure itself. Although we study a single module here, staging of many modules will be required to reach high energy. Furthermore, because of the small dimensions, this structure must be fabricated and assembled precisely by microcircuit-type methods. The small transverse dimension of the device permits a buildup of very high accelerating fields, \sim GeV/m; such large fields in a dielectric structure are possible because the tunneling-ionization breakdown field of the dielectric can become large when exposed to short \sim fs-duration pulses of high field.⁵ A rectangular dielectric slab structure has the advantages that it can pass more beam charge, store more energy, and have better stability to transverse beam deflection than does a cylindrical structure of comparable dimension.

II. Preparation of Femtosecond Duration High Energy Bunches

Techniques have been developed recently to prepare short electron bunches using an inverse free electron laser accelerator (IFEL). This device, which is powered by a CO₂ laser, will bunch electrons on a scale which is a fraction of the laser wavelength. Such bunches are already in use in a staged CO₂ laser IFEL project at ATF, Brookhaven National Laboratory.⁶ However, another CO₂ laser accelerator is under construction by Omega-P at ATF, the LACARA (Laser-driven Cyclotron Autoresonance Accelerator),⁷ which will become operational in 2002. The electron bunch formed by LACARA can be processed (“chopped”) to prepare a train of pC bunches 1 micron in length and spaced by the laser wavelength.⁷ LACARA can prepare this bunch train more accurately and reproducibly than with the IFEL, because the chopping depends only upon the geometry of a fixed chopper “target” in the beamline, rather than on the less precise longitudinal bunching process induced by the laser in the IFEL. In addition to using the upgraded TW CO₂ laser facility at ATF, LACARA also utilizes a 6 T superconducting solenoid which permits a near-resonant interaction that can accelerate the *entire* kA electron bunch (\sim 1 nC in \sim 1 ps). The injection energy is about 50 MeV, and the output energy of this version of a LACARA accelerator can be as high as 100 MeV using a 1 TW CO₂ laser source, obtaining an energy spread of \sim 3%. We shall study the use of the output electron bunches obtained from a similar LACARA-type device, prepared with a novel “chopper” (described below), to excite a small dielectric-lined vacuum structure that might be used in a future high gradient accelerator. The physics and computational methods used to obtain the results presented here are discussed in detail in Ref. [7].

An attractive feature of a wake field structure excited by a train of bunches is shown in Fig. 1, a result of analysis for a microwave-scale planar dielectric wake field accelerator.³ Here ten drive sheet bunches spaced by 10.5 cm pass along the axis of two planar dielectric slabs (alumina) having outer conducting surfaces. The structure is designed such that many TM-like guided modes are excited by the short bunches, and such that the fundamental period of the modes equals the period of the bunch train. The combination of short bunch length and high dielectric constant material favors the creation of sharply-localized pulses of longitudinal electric field. Wake fields from one bunch in a train can be superimposed upon the wake fields from prior bunches: this cumulative effect is shown in Fig. 1. Placement of a test bunch one-half period behind the last drive bunch will allow much higher acceleration

gradients than with only one bunch. The gradient produced may not exceed what can be achieved with a single bunch having a total charge equal to the sum of the charges of all the drive bunches; however it may well be easier to create a train of bunches of moderate charge and high quality than to do so with a single bunch of large charge. A comprehensive theory of wake fields in cylindrical dielectric structures² and analysis of stability for this geometry⁸ have both been recently published. It turns out that the use of the planar geometry (in 3D geometry rather than the 2D example of Fig. 1), while not practical for microwave accelerator structures, is attractive when one considers the use of micron-long, tall rectangular cross-section “sheet” bunches which could excite a 3D rectangular dielectric wake field structure having micron-scale dimensions. In Fig. 2 is shown a schematic of a short rectangular electron bunch traveling between two dielectric layers: the width $2a$ of the channel is $\sim 10\mu$, the thickness $b-a$ of each dielectric layer is $\sim 10\mu$, the length is several cm, and the height H is at least ten times the width. When a tall “sheet” bunch is injected into such a structure, the LSE and LSM modes are excited,⁹ but for a sufficiently tall structure, it is expected that the results will approach the performance of the 2D planar device. This occurs because the LSE modes become weak as the 3D structure height is increased, and the LSM modes will approximate the TM modes of the planar device.

A conceptual schematic of a LACARA device that will form the short bunches is shown in Fig. 3. Noteworthy are the beam stop, the beam focus/defocus quadrupole, and the dielectric wake field structure described above. For a brief summary of the physics involved in LACARA, we mention that a resonance condition exists which connects the laser frequency ω_L to the value of solenoidal magnetic field (expressed in terms of the rest electron gyrofrequency Ω_o) and the particle energy:

$$\Omega_o = \gamma \omega_L (1 - n\beta_z) \quad (1)$$

where the index of refraction $n(r=0, z) = (ck_z/\omega_L)_{r=0} = v_{gr}/c$, where v_{gr} is the axial group velocity, and the phase velocity is ω_L/k_z . The index $n(r, z)$ is written in terms of an “effective” wavenumber that depends on an axial k_z , a radial k_r and (for synchronism) the particle velocity ratio v_r/v_z . The laser fields are obtained from the Gaussian mode, and all components of $\mathbf{E}_L(r, \theta, z)$, $\mathbf{B}_L(r, \theta, z)$, and the components of \mathbf{k} are related by the constant phase condition of the wave $d\psi/dt=0$. The electrons are injected into the interaction region with random phases, but they are rapidly phase-trapped and then accelerated. The electrons receive transverse momentum from the laser field, and the energy exchange is via $\mathbf{v}_\perp \cdot \mathbf{E}_L$. Relativistic equations of motion of particles in the fields allow solutions for the orbits; at each stage of the calculation, the solenoidal field is set to be in resonance to maximize acceleration.

At ATF, the first LACARA is to be operated as an accelerator as described above. However, for the application of making short, rectangular-profile bunches of micron dimensions suitable for wake field acceleration in an “optical” structure, it is necessary to achieve an input bunch to LACARA that has very small emittance. In the following example, this was taken to be a normalized emittance of 1 mm-mrad at an energy of 500 MeV. This emittance is believed to be within the capability of state-of-the-art rf linacs,⁶ and the higher energy is also attractive when staging a sequence of wake field structures which

can accelerate a collinearly-moving test bunch to very high energy. In this application, the LACARA is not used so much as an accelerator, but rather as a “phase-buncher”. The solenoidal field is 1.76 T and is 5 m in length, and a 5 TW CO₂ Gaussian profile laser beam is introduced along the axis of the magnetic field. The bunch charge is taken to be 1 nC in 1 ps in this example, and the input bunch radius is taken to be 30 microns.

In Fig. 4 is shown the acceleration of this bunch of electrons, which is quite small. (In fact, only 1 mJ of energy has been extracted from the 5 J laser pulse in the example discussed; this permits the laser to excite many modules in a staged system.) At the end of the interaction region where the axial field is very weak, the electrons are distributed about an annular ring having radius and thickness depending on the emittance and beam spot size at the input. Figure 5 shows the particle distribution in the $(x-y)$ plane at the end of the device; the motion of the electrons is such that arriving particles have successive loci that circulate around the $(x-y)$ plane at an angular frequency that corresponds to the 35.3 fs period of the 10.6 μ wavelength of the laser that drives the LACARA. Figure 6 shows how the particle distribution varies periodically in x (with the laser period) at the plane of the beam stop. This plane, located at $z = 620\text{cm}$, is also the front face of a 5 cm-thick target beam stop, which contains a small hole for transmitting a fraction of the electrons, shown at the output end of the beam stop at $z = 625\text{cm}$ (Fig. 7). The hole limits transmission of an angular section of the beam profile at the beam stop dimensioned so that the electrons transmitted through it form a pulse of about 3.5 fs in duration (10% of a cycle). The transmitted microbunch charge, for an average current of 1000 A in the full bunch, is 3.5 pC.

The microbunches transmitted by the hole in the beam stop (containing $\sim 2 \times 10^7$ electrons, see Fig. 8) could be used for applications such as creation of very short pulses of x-rays using Compton backscattering off a laser pulse, or injection into the wavelength-scale plasma wake fields set up by the same laser that powers LACARA (thereby maintaining a fixed phase reference for accelerating the injected electrons). However, in what follows, we describe an application in which the emitted chopped bunches are used to set up wake fields in a tall planar dielectric structure, which could be regarded as one modular component out of many for an advanced concept linear accelerator with acceleration gradient $\sim \text{GeV/m}$, that could be used to produce very high energy bunches. (The number of modules would be of the order of 1000 for a TeV accelerator using 500 MeV drive bunches.)

In Fig. 3, a quadrupole focus/defocus element is shown beyond the beam stop that is to prepare a sheet-like beam profile. The quadrupole is located between $z = 630$ and 635cm , and distorts the bunch into a sheet profile at $z \sim 666\text{cm}$; the distribution and profile of the electron bunch are shown in cross section in Fig. 9. The quadrupole magnet produces a pole-face field of 1.05 T with pole radius of 1 cm, and has its axis located at $x = y = 0$. The narrow transverse dimension of the bunch is seen to be 10 μ , and the wide one is about 160 μ (the axial length of the bunch is 1 μ). These bunch dimensions persist for a distance > 10 cm along the axis, which defines the length of the wake field structure.

III. Physics Issues of the Wake Field Device

The choice of a slab beam is motivated by two considerations. First, a slab-shaped electron bunch inside a rectangular dielectric-slab structure has the useful property that an infinitely tall bunch is *entirely* stable against breakup by transverse wakefields;¹⁰ further, if the bunch has *finite* height, the stability is much improved compared with the stability of a cylindrical channel passing comparable bunch charge. To say this somewhat differently, the improvement in stability occurs because the slab channel is passing lower bunch charge per unit height than the comparable cylindrical channel. The transverse wakefield coupling drops from $\sim (\omega_L/c)^3$ in the cylindrical case to $\sim (\sigma_x)^{-3}$ in the rectangular geometry.¹⁰ Thus transmission through small structures can be assured over distances \sim several cm so that correctly phased bunches will pick up or deposit appreciable energy in one stage. Stability of bunch motion in accelerators is always a fundamental issue, and by choosing a tall rectangular cross section one can improve stability while achieving high gradient in the small structure. Of course, stability of an extended system of staged modules could require some external focusing.

Secondly, our work with dielectric wakefield accelerator structures³ has shown that a short charge bunch can excite a high-amplitude well-defined periodic train of axial electric field pulses that trail the bunch on-axis. An example for a 2D rectangular microwave structure using alumina as a dielectric is shown in Fig. 1; it is essential that the dielectric be free of dispersion in order that the fields from the many TM modes excited by the bunch may be exactly superimposed. In the case of the infinite (2D) dielectric slab structure (Fig. 1), the structure *itself* is essentially free of dispersion (unlike the example of cylindrical cross section). To what extent a 3D rectangular structure of finite height, albeit with aspect ratio ~ 20 , approaches the desirable dispersion-free quality of the infinitely tall structure, remains an objective of further study. However, this much we can say: in the 3D structure are set up the ‘‘LSE’’ and ‘‘LSM’’ (LS standing for ‘‘longitudinal-section’’) modes. As the structure becomes very tall and narrow, the LSM dominate, and their dispersion relation becomes the same as the 2D slab in the limit of infinite height. Also, the frequency spacing of the LSM modes becomes nearly constant (and thus the modes are evenly spaced) for height/width ratio > 20 . Thus we expect that the wake fields set up by a bunch in this type of tall rectangular structure will show also the rather clean structure obtained in Ref. 3. The dispersion relation for the modes in the 2D limit yields an expression for mode frequencies $\omega_m = (m+1/2)\Delta\omega$ separated by a constant frequency $\Delta\omega$, where m (an integer) is the mode index, and where

$$\Delta\omega = (\pi\beta c)(b-a)^{-1}(\kappa\beta^2 - 1)^{-1/2}. \quad (2)$$

For a train of bunches separated by 10.6μ , an appropriate choice of dimensions is $2a \sim 10 \mu$ and $b-a \sim 10 \mu$ for dielectric constant $\kappa \sim 3.5$. The Coulomb field of the charge, which is of the same order as the peak wakefield E_z following a 3.5 pC bunch that is 160μ tall, is then $\sim Q_x/2a\epsilon_0$ where Q_x is the bunch charge per unit height (C/m) of the slab bunch; this is $\sim 0.2 \text{ GV/m}$ for just one bunch. From this example, one can appreciate that it is the small size of the structure, intrinsic to the use of laser wavelengths, that favors high accelerating gradients. However, the axial electric field may be increased further by the superposition of several following bunches, each spaced by 10.6μ , obtained from the

original 1 ps (300 μ long) bunch that was prepared by the LACARA. The maximum field strength that can be developed by wakefield superposition is limited by the breakdown field in the dielectric. But we point out that in the wakefield device this is determined by the ~ 5 fs time scale from the passage of a microbunch near an adjacent region of dielectric, and therefore the breakdown field could exceed 3 GV/m.⁵ (It is instructive to note that the rectangular structure will pass more bunch charge with lower field strength at the dielectric than will the cylindrical structure.) The length of the wakefield structure that would contain several “drive” bunches would be only 1 ps, or 0.3 mm; however, the actual length would be set by energy loss rate of the last bunch, ~ 3 GV/m in the example, and therefore a structure ~ 10 – 20 cm in length would be appropriate.

In order to study such accelerating structures, we must be able to transport the chopped electron bunch through the beam shaping apparatus to a location where the beam can be analyzed (e.g., by transition radiation) or where it is accelerated in a wake field structure. The very short dimensions of the bunch suggest that spreading along the direction of motion from the space charge field could be significant. The electric field at the forward or trailing edges of the bunch can be estimated from Gauss’s law as $Q/2A\epsilon_0$, where A is the cross-sectional area of the bunch and Q is the total bunch charge. One then may consider the motion of an electron at the front and at the rear end of the bunch, which move away from the center by Coulomb repulsion. The pulse length increment $\Delta z = z_{front} - z_{back} - 2L$, where $2L$ is the initial bunch length, grows in time t on the z -axis of symmetry approximately as

$$\Delta z \approx eQt^2/2\epsilon_0 Am\gamma^3, \quad (3)$$

where e and m are the electron charge and rest mass, and γ is the relativistic energy factor. An example for a cold beam is shown in Fig. 10. The bunch lengthening effect is quite small on the scale of a single module, and a distance ~ 20 m is seen to be required to double the bunch length. For comparison, if the 500 MeV beam energy spread was $(\delta\gamma/\gamma)_z = 0.1\%$, the resulting spread of longitudinal velocities $\delta v_z = (c/\gamma^2)(\delta\gamma/\gamma)_z$ would double the bunch length in ~ 1 km. Nevertheless, the space charge calculation is crude and the actual spreading depends on the geometry of the cross section and where the electron actually is located. For this, a study of pulse spreading using a PIC code is indicated; however, our estimate suggests that the chopped pulse can be processed and transported to remote location without the use of plasma for neutralization.

A problem that affects all device structures in which a highly relativistic electron bunch must pass through an aperture is the “coherent diffraction radiation”,¹¹ a form of transition radiation in which some of the Poynting flux associated with the moving bunch is intercepted by the dielectric or metal structure and is lost from the bunch. In CGS units, the ratio of the energy lost by the bunch to its incident bunch energy $\sim \gamma Nmc^2$ for the rectangular slab device, is

$$\frac{1}{16\pi^2 m_0 c^2} \frac{Ne^2}{H} \ln\left(\frac{H}{a}\right) \sim 10^{-5}, \quad (4)$$

and therefore presents no serious obstacle for an accelerator up to TeV energy, since only about 10 MeV would be lost to diffraction radiation per stage. However, if a single bunch were to be used having charge equal to that of the full train of 30 microbunches, then its diffraction radiation might amount to 300 MeV per stage, clearly an intolerable magnitude.

Wakefield structures are attractive because no external source of energy is used to excite the structure itself. Thus no new source of energy is needed for the optical wakefield accelerator structure, other than the CO₂ laser source that generates the macrobunch in LACARA. The beam could be refocused into sheet configuration downstream periodically by quadrupole magnets located between the staged wake field accelerator units. The breakdown limit of the wakefield structure is not determined by the slow filling time of the structure by electromagnetic energy, but rather by the much shorter time of the passing field pulses set up by the short (micro) bunches. The breakdown problem in connection with rf energy “slowly” filling the cavities of a conventional linac, also applies to optical energy “slowly” filling an optical Fabry-Perot resonator.¹² The use of a train of fs bunches to build up the accelerating field in an “optical” wakefield structure should have superior breakdown field properties to the optical resonator, and also should be competitive with the laser-wakefield plasma accelerator which is under intensive investigation. The proposed vacuum-based wakefield structure can be mechanically rigid and therefore should be a more reproducible and controllable element in a staged system than would be an array of pulsed plasma elements. Further work must be done to identify and develop broadband transparent, high dielectric constant materials suitable for these optical-scale wake field structures, as well as to develop a transport lattice for multi-stage operation. The structure is capable of micro-fabrication accuracy, an important consideration when staging a large number of modules. Finally, the charge of a sequence of “drive” bunches can be programmed¹³ so that the charge of a train of bunches increases progressively according to a certain relationship,¹⁴ permitting a considerable increase in the “transformer ratio”.

Fig. 1. Cumulative wake field set up by 10 identical successive sheet bunches in a tuned microwave-scale dielectric slab structure, at the time the first bunch has moved 100 cm along the structure. Bunch locations are shown by black dots at bottom of figure.

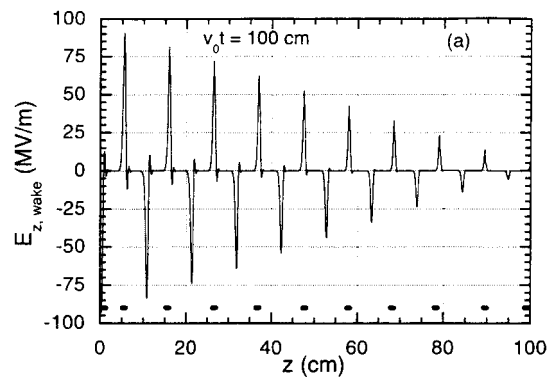

Fig. 2. Schematic of slab bunch within a planar optical wake field structure.

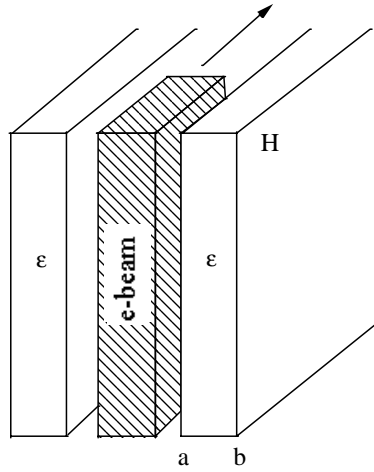

Fig. 3. Schematic of LACARA with beam stop inserted to produce a chopped beam that is formed into a sheet-like transverse profile using a quadrupole, for generation of intense wake fields in a planar dielectric accelerating structure. Radial scale is expanded for clarity.

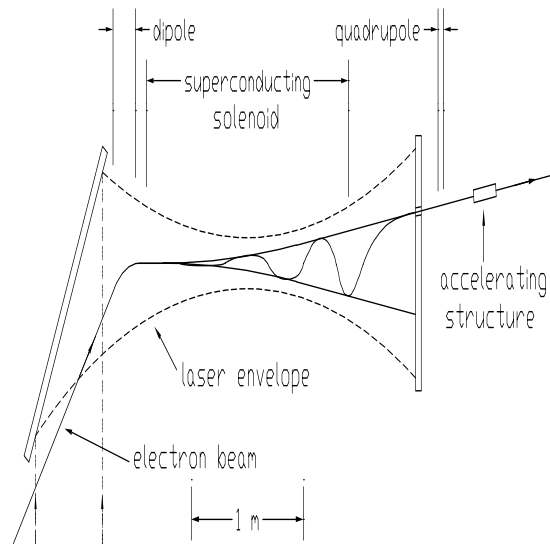

Fig. 4. Magnetic field profile and gain of energy of an electron bunch in LACARA, using a 5 TW circularly polarized CO₂ laser in a Gaussian beam with 266.7 cm Rayleigh range. The beam stop extends from $z = 620$ to 625 cm; the quadrupole is located between $z = 630$ to 635 cm.

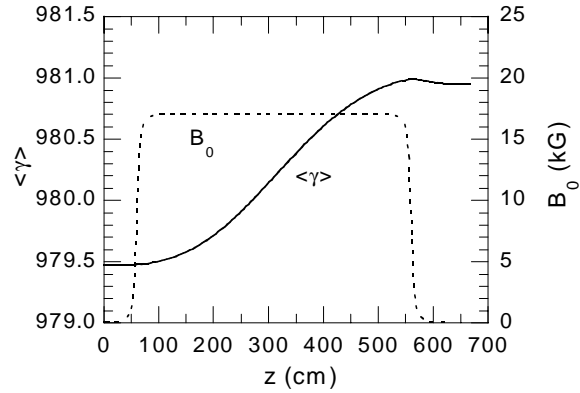

Fig. 5. Particle distribution in x - y plane at $z = 620$ cm at the end of LACARA. The input bunch radius is 30 microns, and the input beam normalized emittance is 1 mm-mrad.

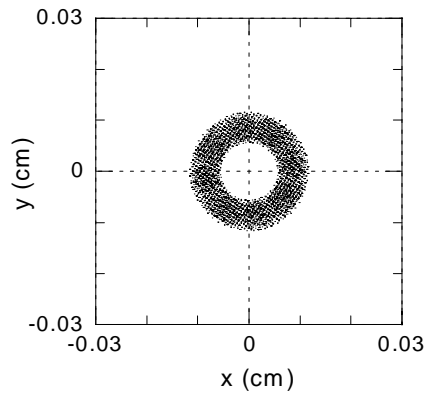

Fig. 6. Particle distribution Δt vs. x at $z = 620$ cm.

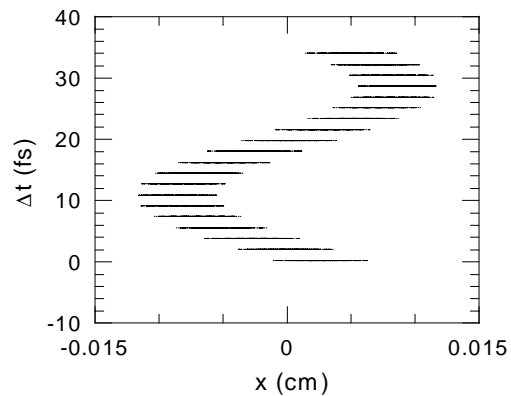

Fig. 7. Particle distribution in x - y plane at $z = 625$ cm (back of stop).

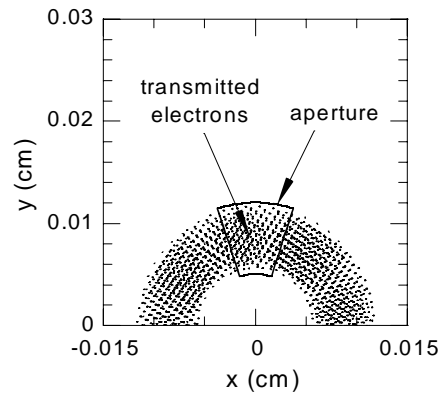

Fig. 8. Current transmitted by the beam stop aperture vs. time at $z = 625$ cm.

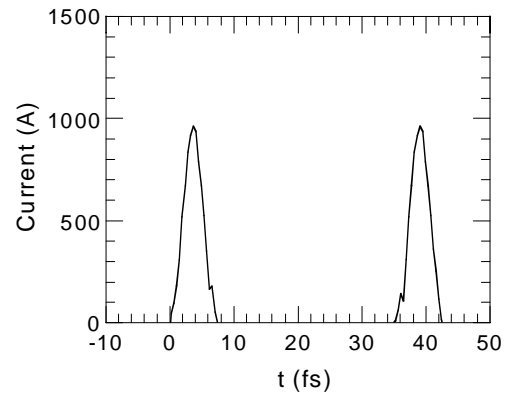

Fig. 9. Sheet beam profiles (a), and narrow-dimension distribution functions (b), following the quadrupole, at $z = 666$ and 671 cm. Note that x and y scales are different in Fig. 9(a).

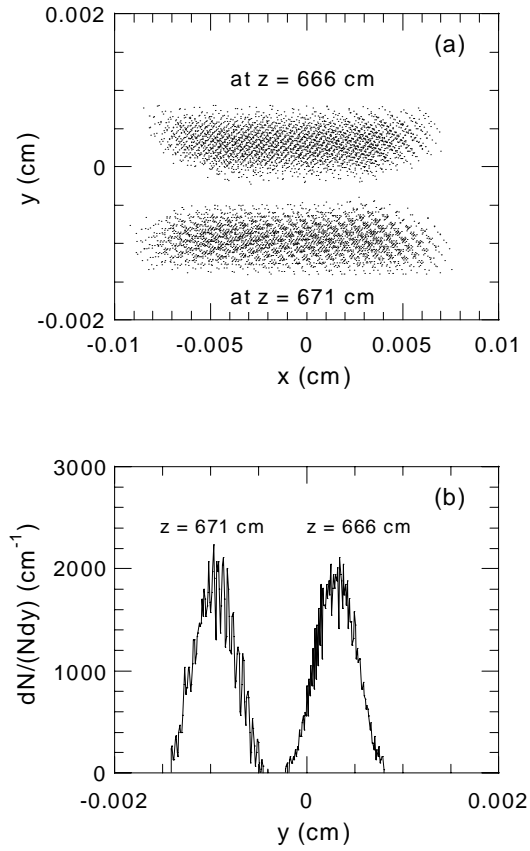
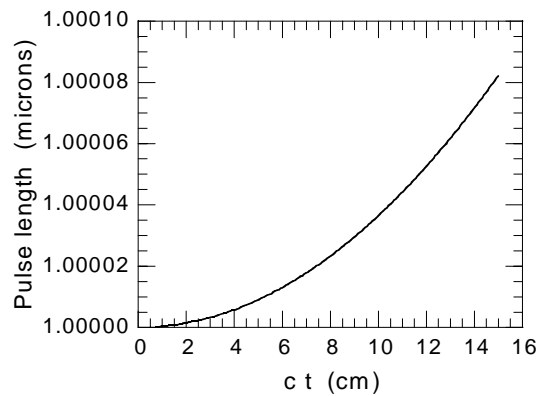

Fig. 10. Space charge expansion of beam bunch length for a 10 micron high, 160 micron wide bunch of charge 3.5 pC (the beam is assumed to be cold).



-
- ¹ E. Esarey, P. Sprangle, J. Krall and A. Ting, IEEE Trans. Plasma Science **24**, p. 252 (1996).
- ² S. Y. Park and J. L. Hirshfield, Phys. Rev. **E 62**, p. 1266 (2000).
- ³ T-B. Zhang, J. L. Hirshfield, T. C. Marshall and B. Hafizi, Phys. Rev. **E 56**, p. 4647 (1997).
- ⁴ T. C. Marshall, J-M. Fang, J. L. Hirshfield, and S. Y. Park in *Advanced Accelerator Concepts*, 2000, (AIP, New York, 2001), (to be published).
- ⁵ P. Sprangle, B. Hafizi and R. F. Hubbard, Phys. Rev. **E 55**, p. 5964 (1997).
- ⁶ W. D. Kimura et al, Phys. Rev. Lett. **86**, p. 4041 (2001).
- ⁷ C. Wang and J. L. Hirshfield, Phys. Rev. **E 61**, p. 7252 (2000).
- ⁸ S. Y. Park and J. L. Hirshfield, Phys. Plasmas **8**, p. 2461 (2001).
- ⁹ R. E. Collin, in *Field Theory of Guided Waves* (IEEE Press, New York, 1991).
- ¹⁰ A. Tremaine, J. Rosenzweig and P. Schoessow, Phys. Rev. **E 56**, p. 7204 (1997).
- ¹¹ M. Castellano et al, Phys. Rev. **E 63**, p. 056501 (2001).
- ¹² J. Rosenzweig and P. Schoessow in *Advanced Accelerator Concepts, 8th Workshop*, 1998, edited by W. Lawson, C. Bellamy, and D. Brosius, (AIP, New York, 1999), p. 693; see also J. Rosenzweig, A. Murokh, and C. Pellegrini, Phys. Rev. Lett. **74**, p. 2467 (1995).
- ¹³ K. L. Bane, P. Chen and P. B. Wilson, IEEE Trans. Nucl. Sci. **32**, p. 3524 (1985).
- ¹⁴ J. G. Power, W. Gai, and A. Kanareykin in *Advanced Accelerator Concepts, 9th Workshop*, 2000, (AIP, New York, 2001), (to be published).